

Pilar	Q <sub>ax</sub>	V <sub>ax</sub>
S1	1000.0	1000.0
S2	1000.0	1000.0
S3	1000.0	1000.0
S4	1000.0	1000.0
S5	1000.0	1000.0
S6	1000.0	1000.0
S7	1000.0	1000.0
S8	1000.0	1000.0
S9	1000.0	1000.0
S10	1000.0	1000.0
S11	1000.0	1000.0
S12	1000.0	1000.0
S13	1000.0	1000.0

**SAPATAS CONCRETO COM FCK DE 25 MPa**  
S1 até S13  
(ESCALA 1:25)

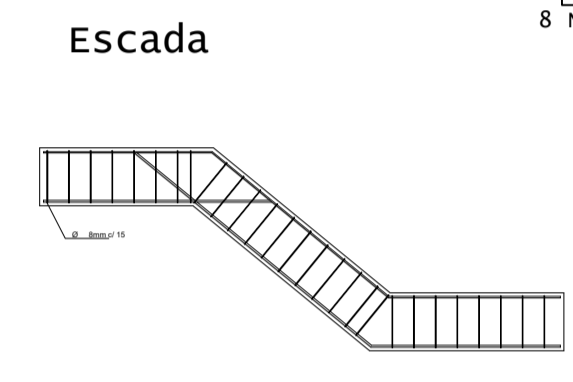
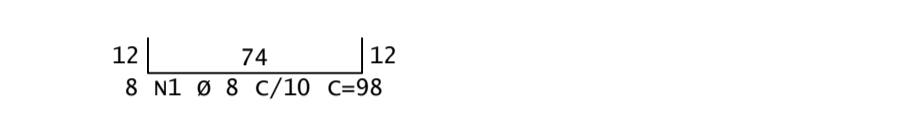
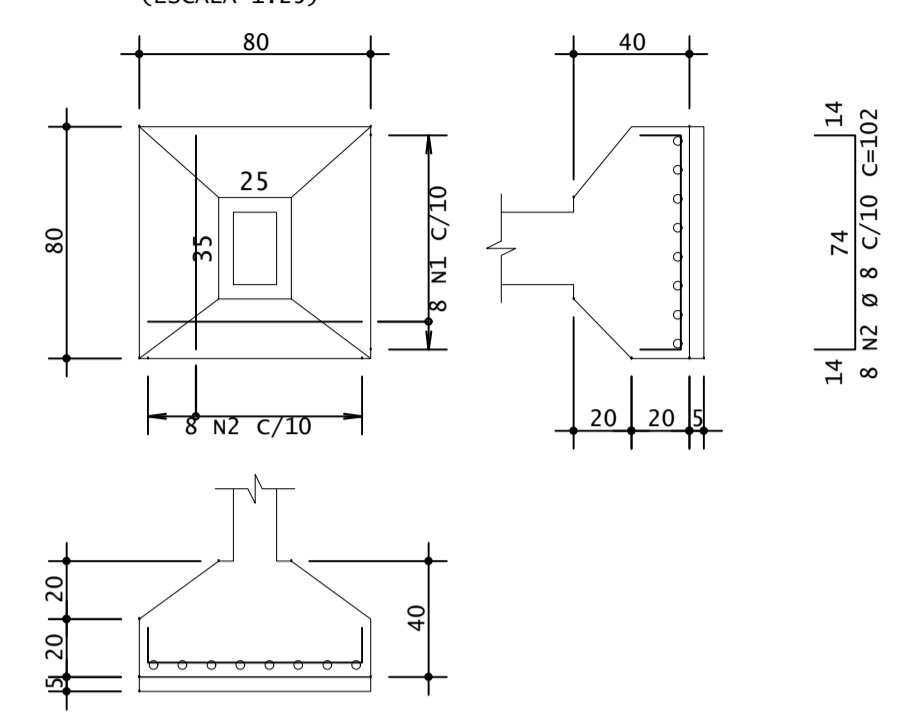

**BROCA Ø 20**  
Profundidade: Até achar solo resistente

**Viga Baldrame**

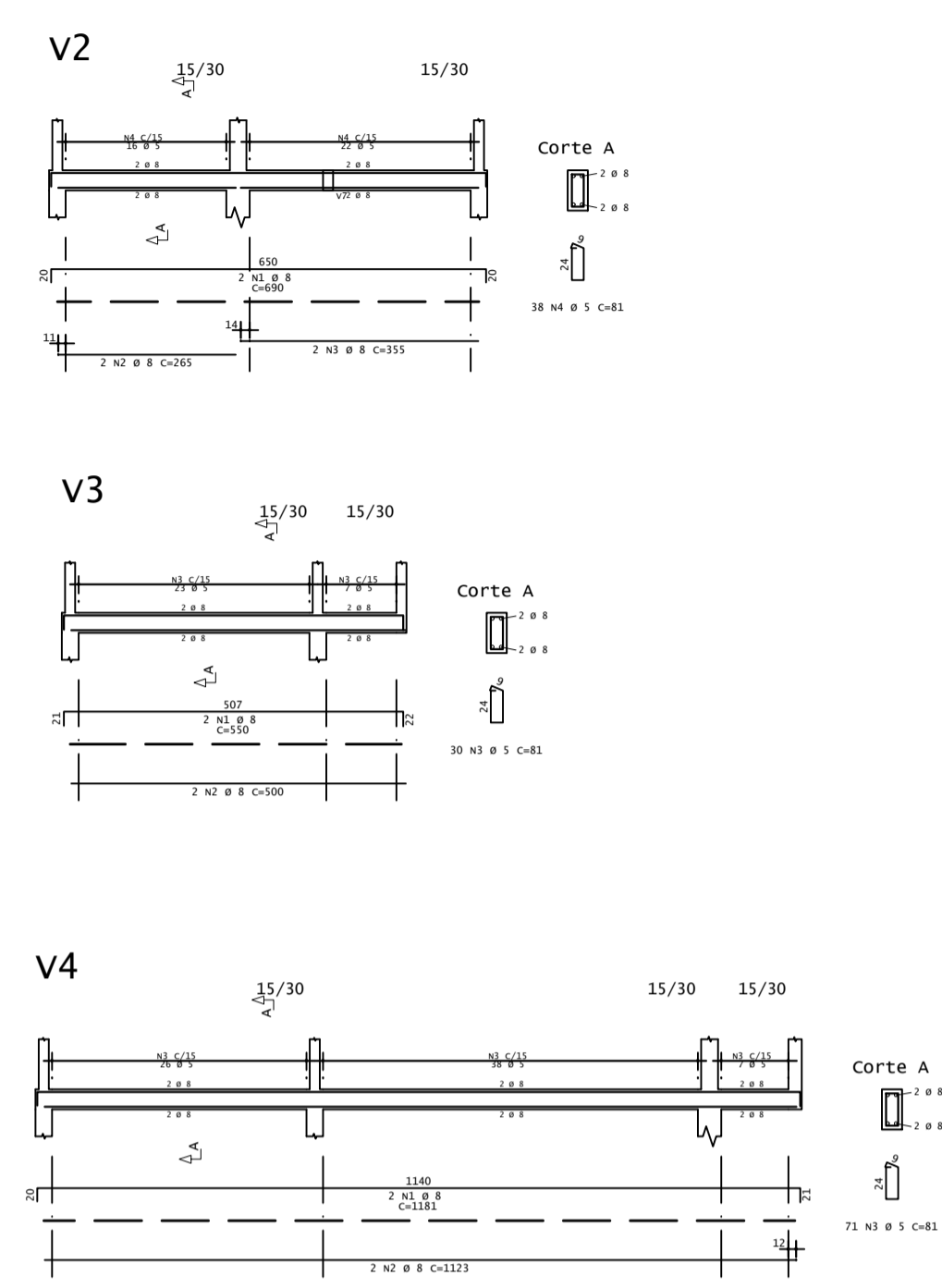

**CONCRETO COM FCK DE 25 MPa**

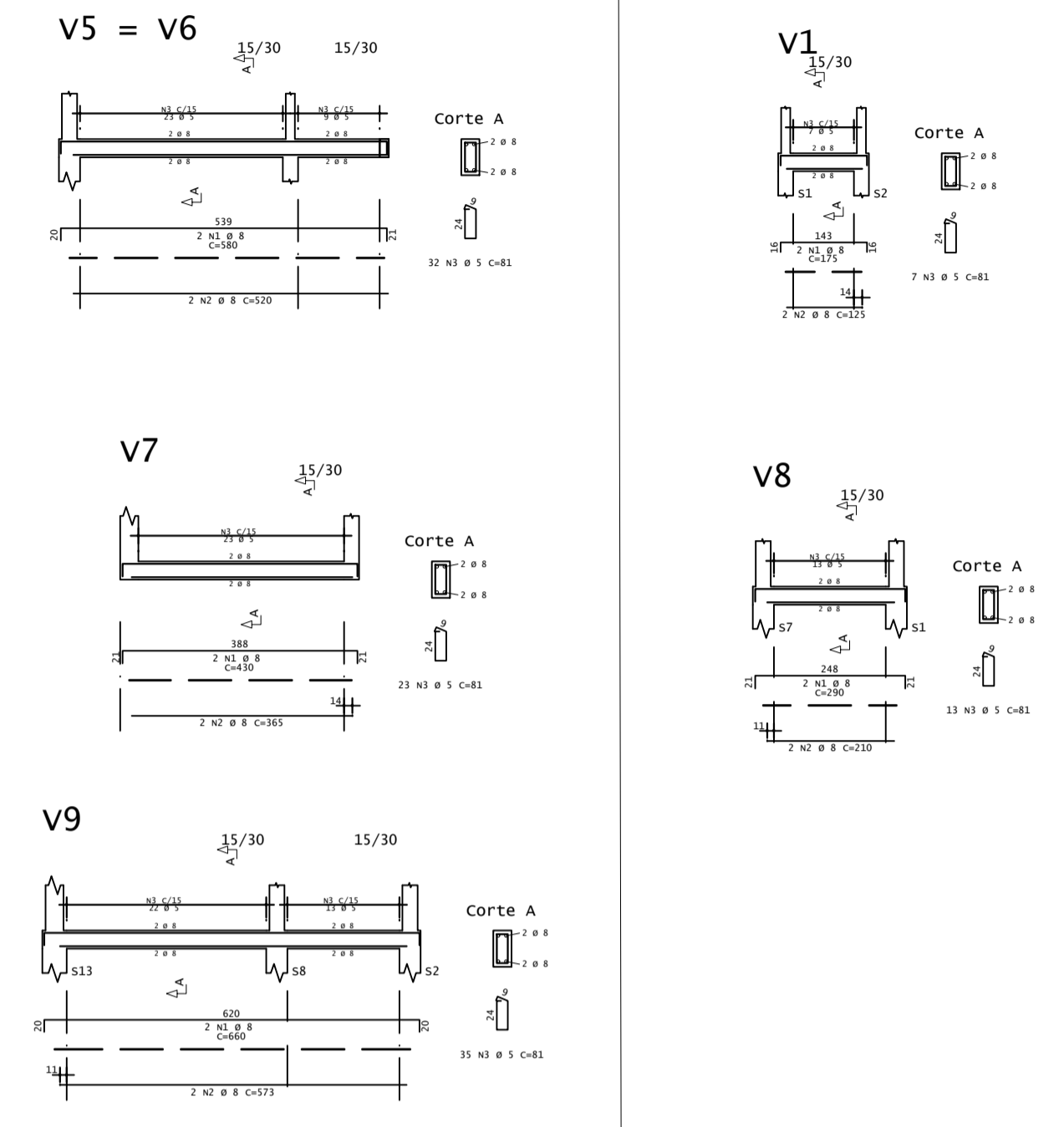

**PILARES**

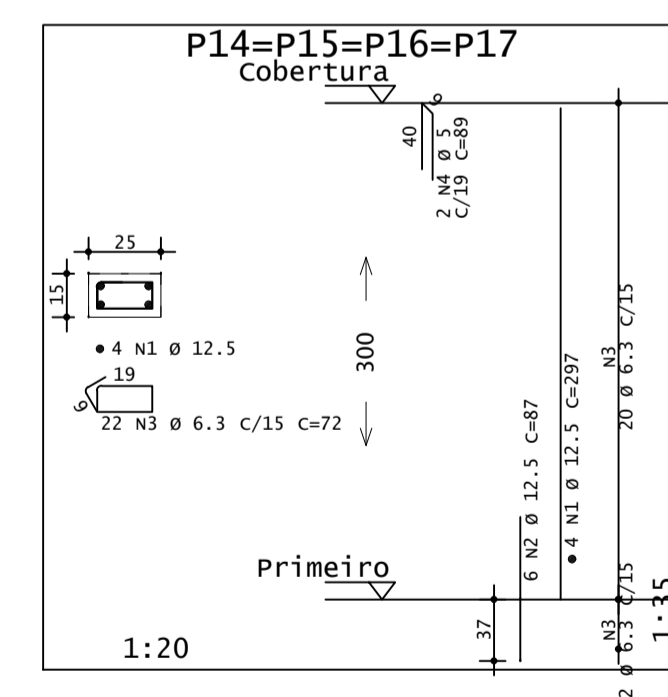
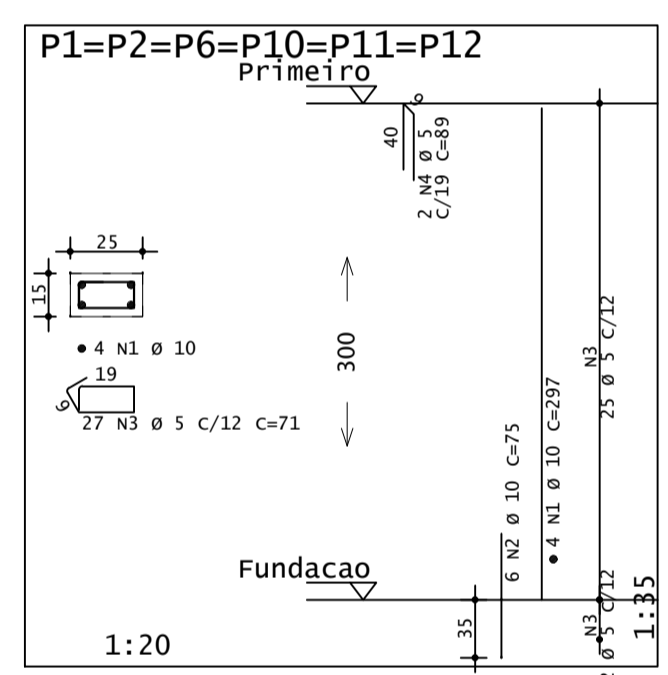

**CONCRETO COM FCK DE 25 MPa**

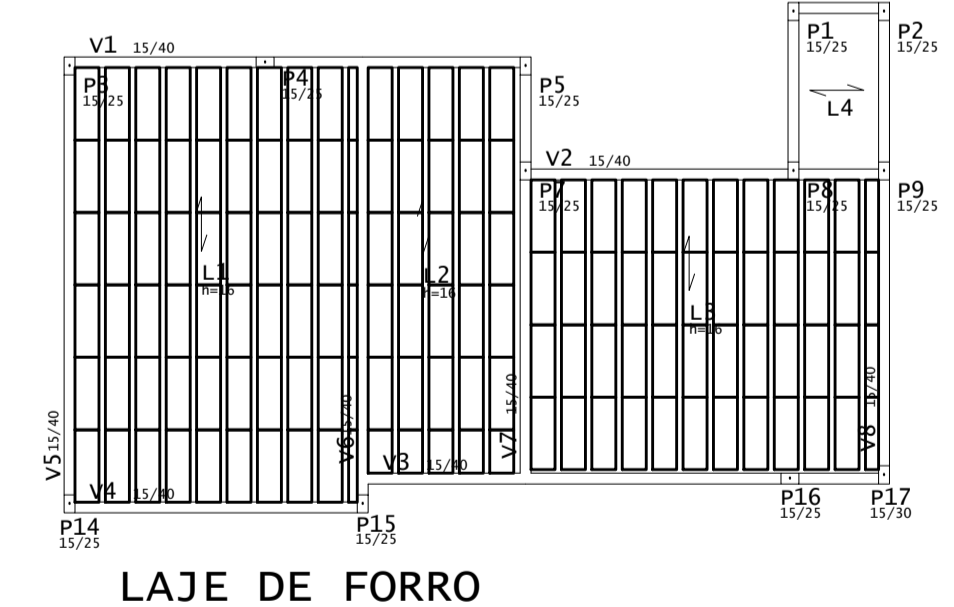
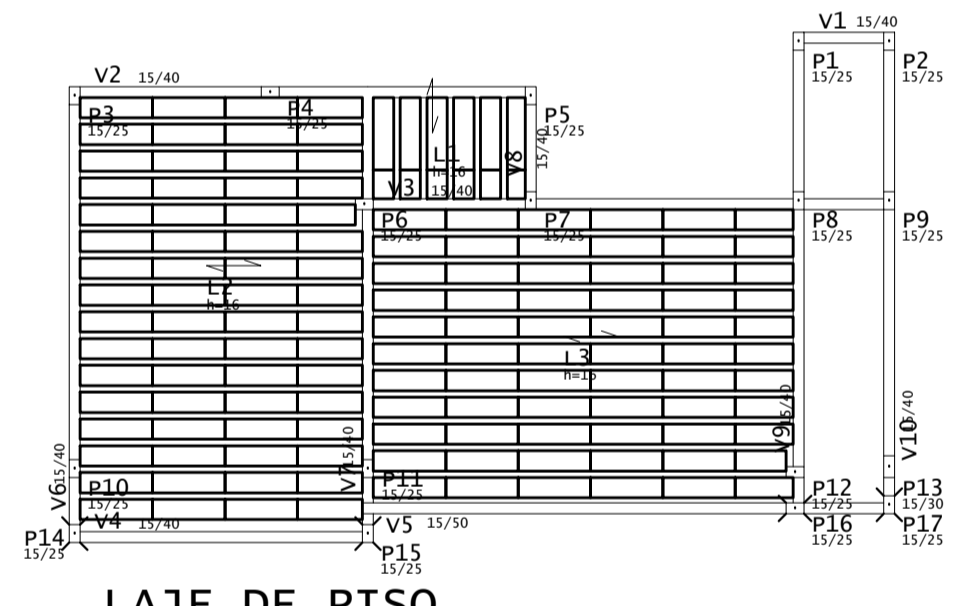
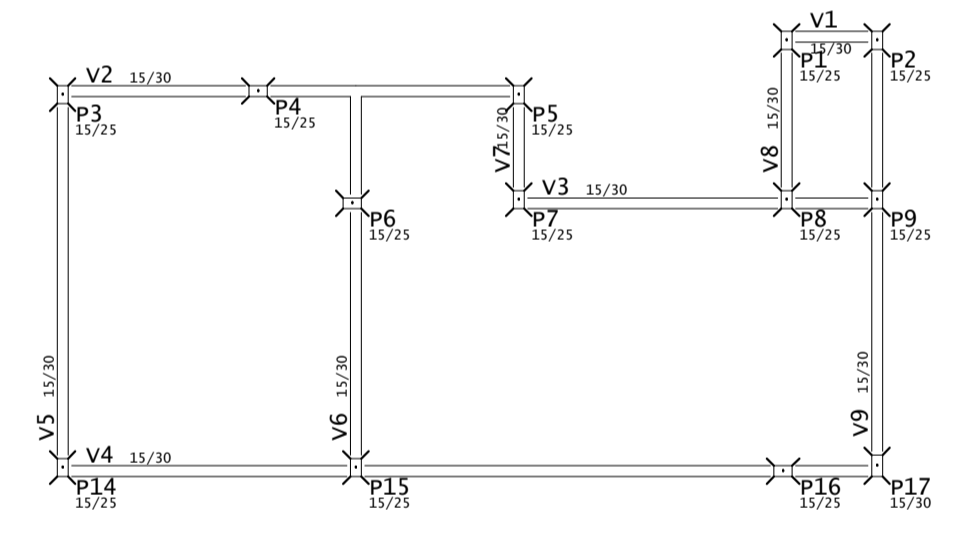
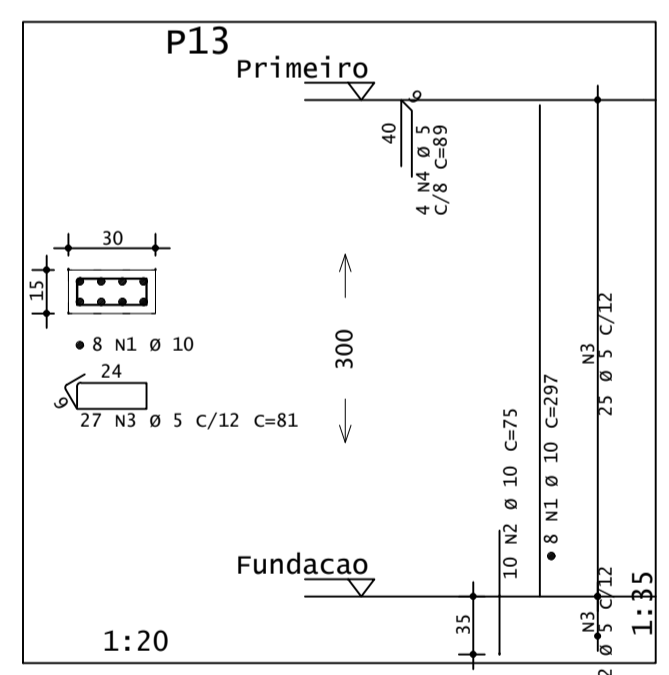
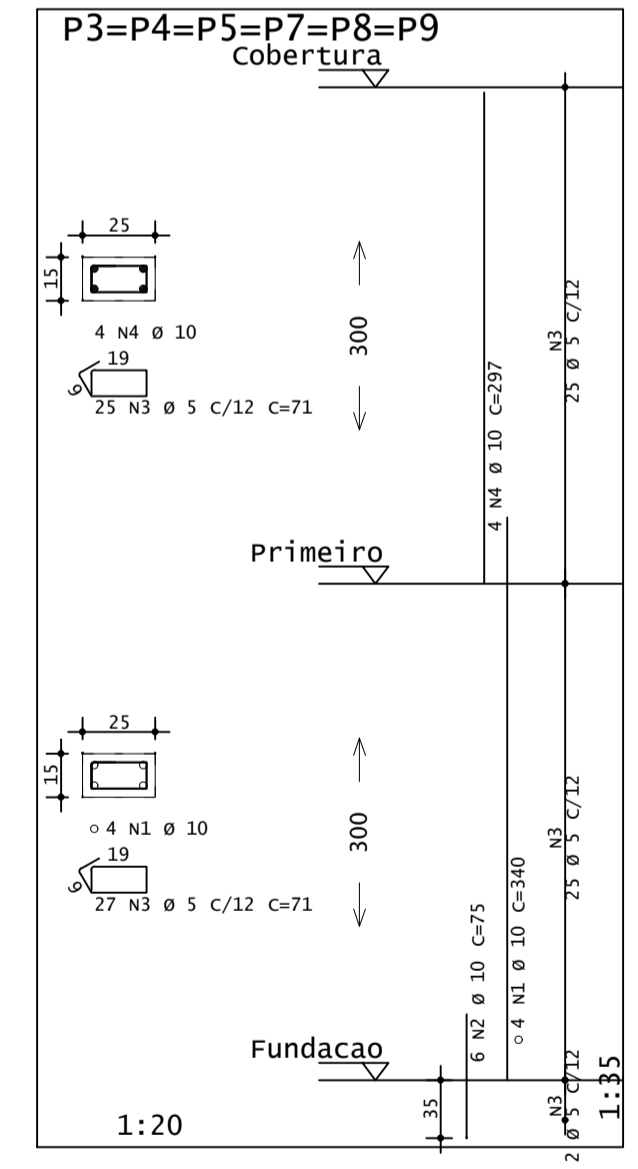

**PROJETO ESTRUTURAL**

Obra: AMPLIAÇÃO  
Proprietário: CÂMARA MUNICIPAL DE INCONFIDENTES - MG  
Local: RUA ENGENHEIRO ALVARES MACIEL - 70 CENTRO  
Cidade: INCONFIDENTES - MG  
Data: 02/07/2019

CÂMARA MUN. INCONFIDENTES C.N.P.J. 02.334.389/0001-31  
Patrícia Lambert Moreira Arquiteta e Urbanista CAU/MG - A 41745-9